



## IGBT Modules

V<sub>CES</sub>            1200V  
I<sub>C</sub>                 50A

## Applications

- Inverter for motor drive
- AC and DC servo drive amplifier
- UPS (Uninterruptible Power Supplies)
- Soft switching welding machine

## Features

- Low V<sub>ce(sat)</sub> with Trench technology
- V<sub>ce(sat)</sub> with positive temperature coefficient
- High short circuit capability(10us)
- Including ultra fast & soft recovery anti-parallel FWD
- Low inductance
- Maximum junction temperature 175°C

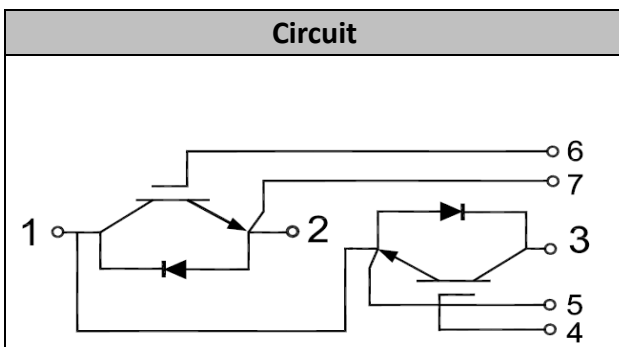

## ● IGBT

### Absolute Maximum Ratings

Parameter	Symbol	Conditions	Value	Unit
Collector-Emitter Voltage	V <sub>CES</sub>	V <sub>GE</sub> =0V, I <sub>C</sub> =1mA, T <sub>vj</sub> =25°C	1200	V
Continuous Collector Current	I <sub>C</sub>	T <sub>c</sub> =100°C	50	A
Repetitive Peak Collector Current	I <sub>CRM</sub>	t <sub>p</sub> =1ms	100	A
Gate-Emitter Voltage	V <sub>GES</sub>	T <sub>vj</sub> =25°C	± 20	V
Total Power Dissipation	P <sub>tot</sub>	T <sub>c</sub> =25°C T <sub>vjmax</sub> =175°C	485	W



### Characteristic values

Parameter	Symbol	Conditions	Value			Unit	
			Min.	Typ.	Max.		
Gate-emitter Threshold Voltage	$V_{GE(th)}$	$V_{GE}=V_{CE}, I_C=3mA, T_{vj}=25^{\circ}C$	5.0	6.2	7.0	V	
Collector-Emitter Cut-off Current	$I_{CES}$	$V_{CE}=1200V, V_{GE}=0V, T_{vj}=25^{\circ}C$			1.0	mA	
Collector-Emitter Saturation Voltage	$V_{CE(sat)}$	$I_C=50A, V_{GE}=15V, T_{vj}=25^{\circ}C$		1.85		V	
		$I_C=50A, V_{GE}=15V, T_{vj}=125^{\circ}C$		2.05			
Input Capacitance	$C_{ies}$	$V_{CE}=25V, V_{GE}=0V,$ $f=1MHz, T_{vj}=25^{\circ}C$		4.29		nF	
Reverse Transfer Capacitance	$C_{res}$			0.20		nF	
Gate-Emitter leakage current	$I_{GES}$	$V_{CE}=0V, V_{GE}=20V, T_{vj}=25^{\circ}C$			400	nA	
Turn-on Delay Time	$t_{d(on)}$	$I_C=50A$ $V_{CE}=600V$ $V_{GE}=\pm 15V$ $R_G=15\Omega$ $T_{vj}=25^{\circ}C$		150		ns	
Rise Time	$t_r$			75		ns	
Turn-off Delay Time	$t_{d(off)}$			379		ns	
Fall Time	$t_f$			288		ns	
Energy Dissipation During Turn-on Time	$E_{on}$			6.2		mJ	
Energy Dissipation During Turn-off Time	$E_{off}$			3.3		mJ	
Turn-on Delay Time	$t_{d(on)}$		$I_C=50A$ $V_{CE}=600V$ $V_{GE}=\pm 15V$ $R_G=15\Omega$ $T_{vj}=125^{\circ}C$		388		ns
Rise Time	$t_r$				76		ns
Turn-off Delay Time	$t_{d(off)}$				411		ns
Fall Time	$t_f$				344		ns
Energy Dissipation During Turn-on Time	$E_{on}$			6.8		mJ	
Energy Dissipation During Turn-off Time	$E_{off}$			4.4		mJ	
SC Data	$I_{sc}$	$T_p \leq 10\mu s, V_{GE}=15V,$ $T_{vj}=150^{\circ}C, V_{cc}=600V,$ $V_{CEM} \leq 1200V$			272		A



## ● Diode

### Absolute Maximum Ratings

Parameter	Symbol	Conditions	Value	Unit
Repetitive Peak Reverse Voltage	$V_{RRM}$	$T_{vj}=25^{\circ}C$	1200	V
Continuous DC Forward Current	$I_F$		50	A
Repetitive Peak Forward Current	$I_{FRM}$	$t_p=1ms$	100	A

### Characteristic values

Parameter	Symbol	Conditions	Value			Unit
			Min.	Typ.	Max.	
Forward Voltage	$V_F$	$I_F=50A, T_{vj}=25^{\circ}C$		1.95	2.20	V
		$I_F=50A, T_{vj}=125^{\circ}C$		2.05		
Recovered Charge	$Q_{rr}$	$I_F=50A$		2.77		$\mu C$
Peak Reverse Recovery Current	$I_{rr}$	$V_R=600V$ $-di_F/dt=800A/\mu s$		30		A
Reverse Recovery Energy	$E_{rec}$	$T_{vj}=25^{\circ}C$		0.65		mJ
Recovered Charge	$Q_{rr}$	$I_F=50A$		6.39		$\mu C$
Peak Reverse Recovery Current	$I_{rr}$	$V_R=600V$ $-di_F/dt=800A/\mu s$		31		A
Reverse Recovery Energy	$E_{rec}$	$T_{vj}=125^{\circ}C$		2.16		mJ



## ● Module Characteristics

 $T_C=25^{\circ}\text{C}$  unless otherwise specified

Parameter	Symbol	Conditions	Value			Unit
			Min.	Typ.	Max.	
Isolation voltage	$V_{\text{isol}}$	$t=1\text{min}, f=50\text{Hz}$	2500			V
Maximum Junction Temperature	$T_{\text{jmax}}$				175	$^{\circ}\text{C}$
Operating Junction Temperature	$T_{\text{vjop}}$		-40		150	$^{\circ}\text{C}$
Storage Temperature	$T_{\text{stg}}$		-40		125	$^{\circ}\text{C}$
Thermal Resistance Junction-to Case	$R_{\theta\text{JC}}$	per IGBT			0.31	K/W
		per Diode			0.57	
Thermal Resistance Case-to Sink	$R_{\theta\text{CS}}$	Conductive grease applied		0.05		K/W
Module Electrodes Torque	$M_t$	Recommended(M5)	2.5		5.0	N·m
Module-to-Sink Torque	$M_s$	Recommended(M6)	3.0		5.0	N·m
Weight of Module	G			150		g

